

DOBIKON 1012
Installation Manual

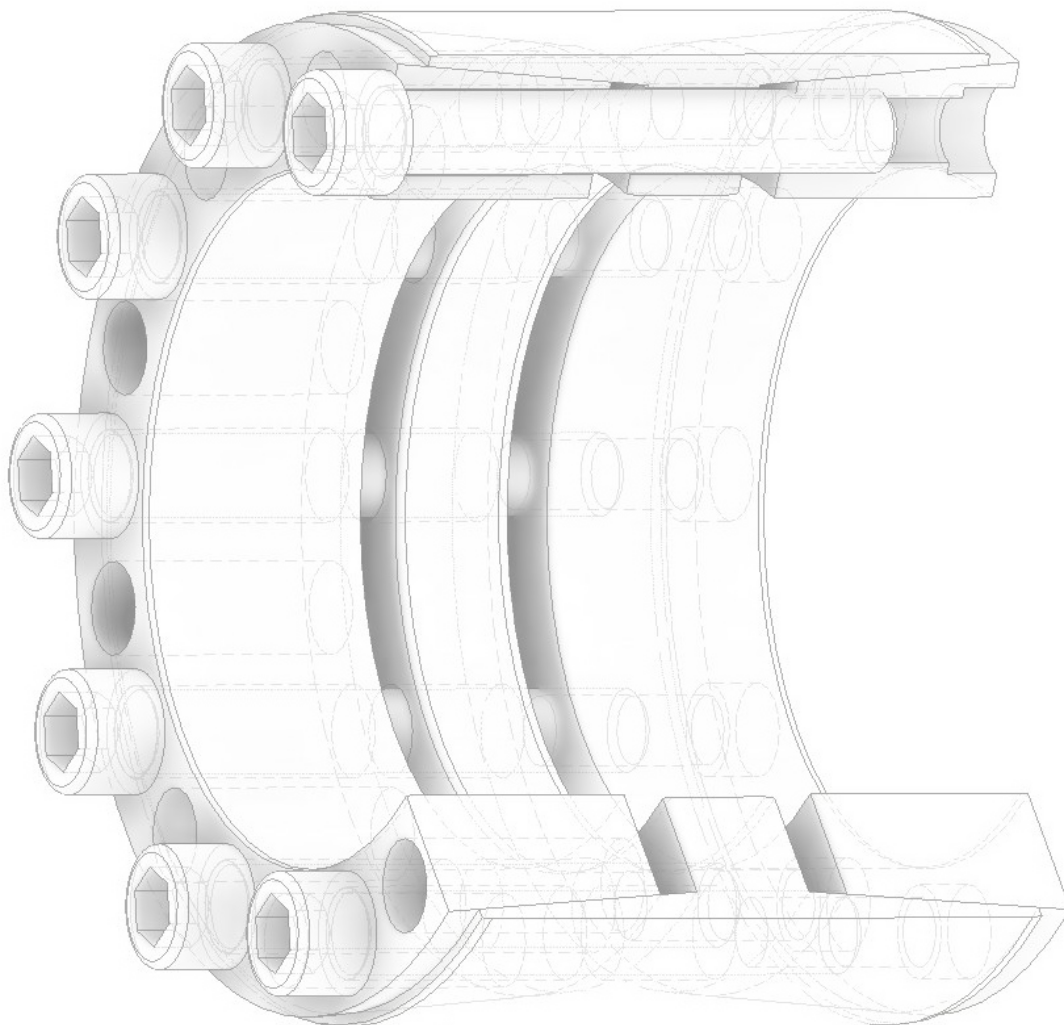

Only available from BIKON-Technik GmbH • 41468 Neuss • Germany

A Development of BIKON-Technik GmbH - introduction on global market in year 1974

Index:

We reserve all rights with regard to this technical data and its content. Without our prior written approval it is not allowed to duplicate this technical data or parts of it, nor to grant access to it by third parties or to exploit it otherwise (including extracts) without authority.

All topics and specification dealt with are only valid for original „BIKON“ or „DOBIKON“ products.

We will not accept any liability for damages arising from misinterpretation, application or constructional flaws (regarding equipment wherein our products shall be installed). All information is based upon our knowledge of the current state of the art at the draft date of this technical data.

We refer to our trademark and further intellectual property rights as well as our conditions of sale that shall apply.

April 2023



BIKON-Technik GmbH

Hansemannstrasse 11 · 41468 Neuss · Germany
Tel. ++49 (0) 2131-71889-0 · www.bikon.de · E-Mail: info@bikon.de

Schematic scetch

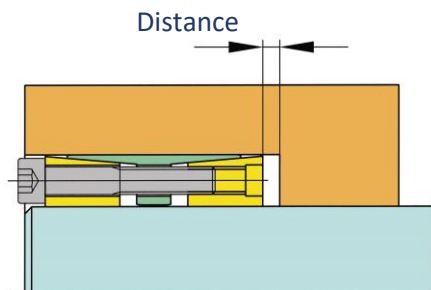

Space - generally

By use of stepped bores the locking assembly should never be pushed to block against the hub. There must be let distance about 2 – 5 mm to the hub to be able to remove the rings from each other. This applies to all BIKON locking assemblies.

Shafts with keyways

DOBIKON Locking assemblies can be tighten over keyways (according to DIN) on shafts. The function of the locking assembly is not affected.

Keyways in the hub are not allowed !

Space - DOBIKON 1012

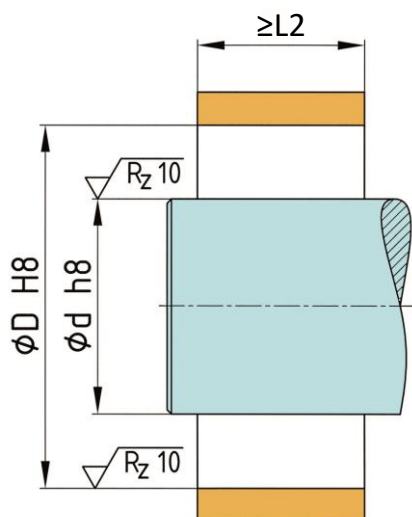

d	D	L2	d	D	L2	d	D	L2
mm	mm	mm	mm	mm	mm	mm	mm	mm
25	55	40	90	130	78	300	375	180
28	55	40	95	135	78	320	405	180
30	55	40	100	145	100	340	425	180
35	60	54	110	155	100	360	455	206
38	75	54	120	165	100	380	475	206
40	75	54	130	180	114	400	495	206
42	75	54	140	190	114	420	515	206
45	75	54	150	200	114	440	535	206
48	80	64	160	210	114	460	555	206
50	80	64	170	225	148	480	575	210
55	85	64	180	235	148	500	595	210
60	90	64	190	250	148	520	615	210
65	95	64	200	260	148	540	635	210
70	110	78	220	285	150	560	655	210
75	115	78	240	305	150	580	675	210
80	120	78	260	325	150	600	695	210
85	125	78	280	355	180			

TA – Tightening torque of screws

d	M	TA	d	M	TA	d	M	TA	d	M	TA
mm	-	Nm	mm	-	Nm	mm	-	Nm	mm	-	Nm
25	M6	17	70	M10	83	170	M16	355	400	M22	930
28	M6	17	75	M10	83	180	M16	355	420	M22	930
30	M6	17	80	M10	83	190	M16	355	440	M22	930
35	M8	41	85	M10	83	200	M16	355	460	M22	930
38	M8	41	90	M10	83	220	M16	355	480	M22	930
40	M8	41	95	M10	83	240	M16	355	500	M22	930
42	M8	41	100	M12	145	260	M16	355	520	M22	930
45	M8	41	110	M12	145	280	M20	690	540	M22	930
48	M8	41	120	M12	145	300	M20	690	560	M22	930
50	M8	41	130	M14	230	320	M20	690	580	M22	930
55	M8	41	140	M14	230	340	M20	690	600	M22	930
60	M8	41	150	M14	230	360	M22	930			
65	M8	41	160	M14	230	380	M22	930			

Installation

1.

DOBIKON locking assemblies are delivered ready for installation and oiled. The screws have been unscrewed a few threads.

Make sure that the rings fit loosely on top of each other (self-locking cone).

If the locking assembly is to be dismantled into its individual parts, please mark the position of the rings in relation to each other!

The slits are offset and not aligned, nor should they be aligned with each other.

From $d = 180$ mm the outer rings are not slitted.

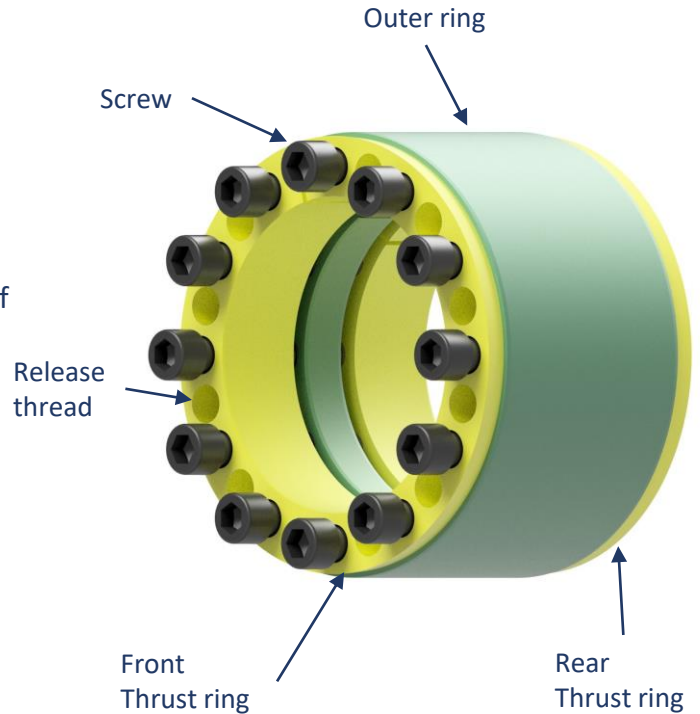

2.

Oil the shaft and hub and push the locking assembly into the installation space.

Do not use molybdenum disulfide (MoS₂), assembly paste or grease!

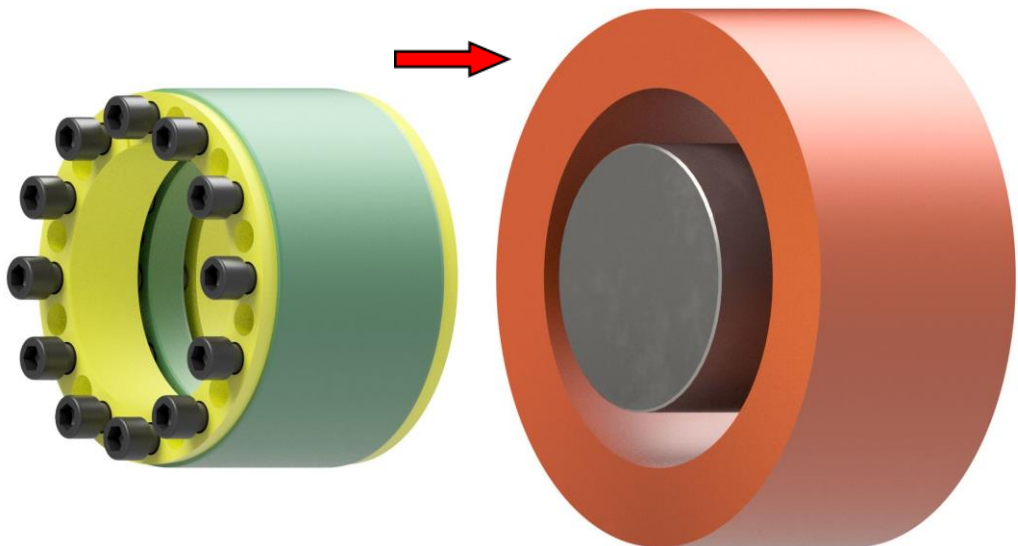

Installation

3.

The locking assembly must sit flush with the hub.

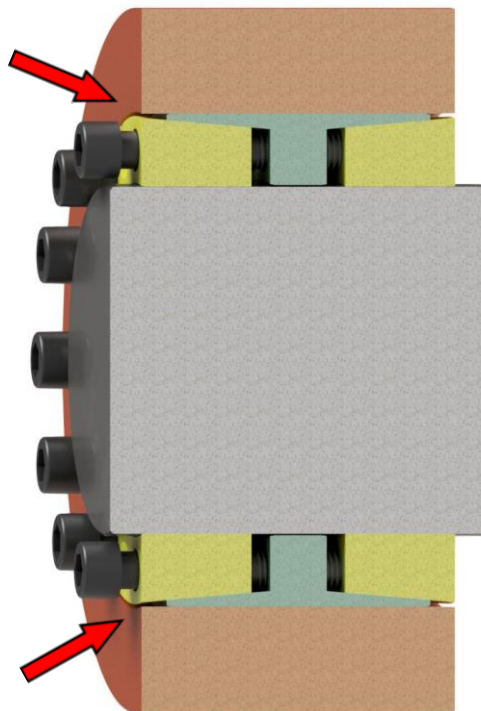

4.

Tighten the screws evenly crosswise and in several stages using a torque wrench.

control !

The tightening of the screws and the assembly is complete when no more screws can be tightened with the 100% tightening torque.

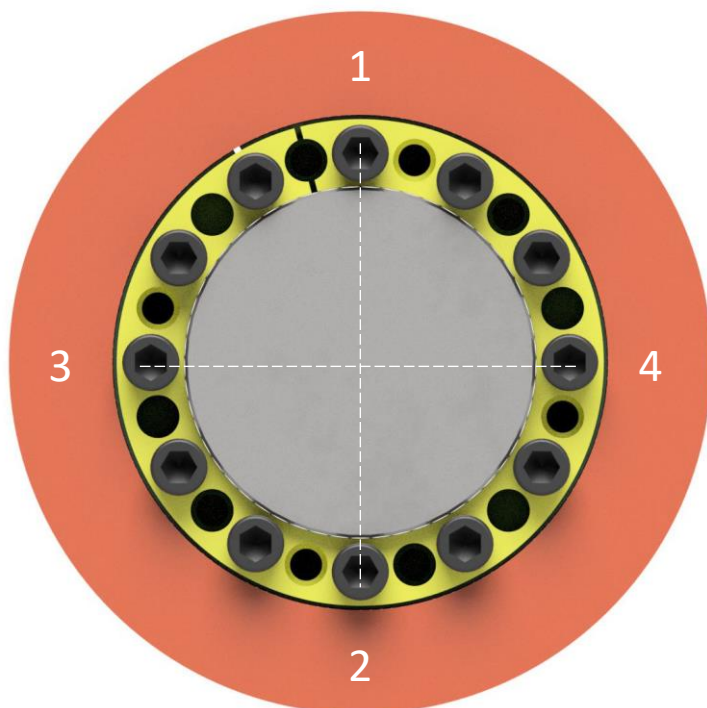

Installation

5.

By tightening the screws, the thrust rings slides and tightens the connection. The cone is self-locking and will not loosen by itself if the screws are loosened if it is operated properly.

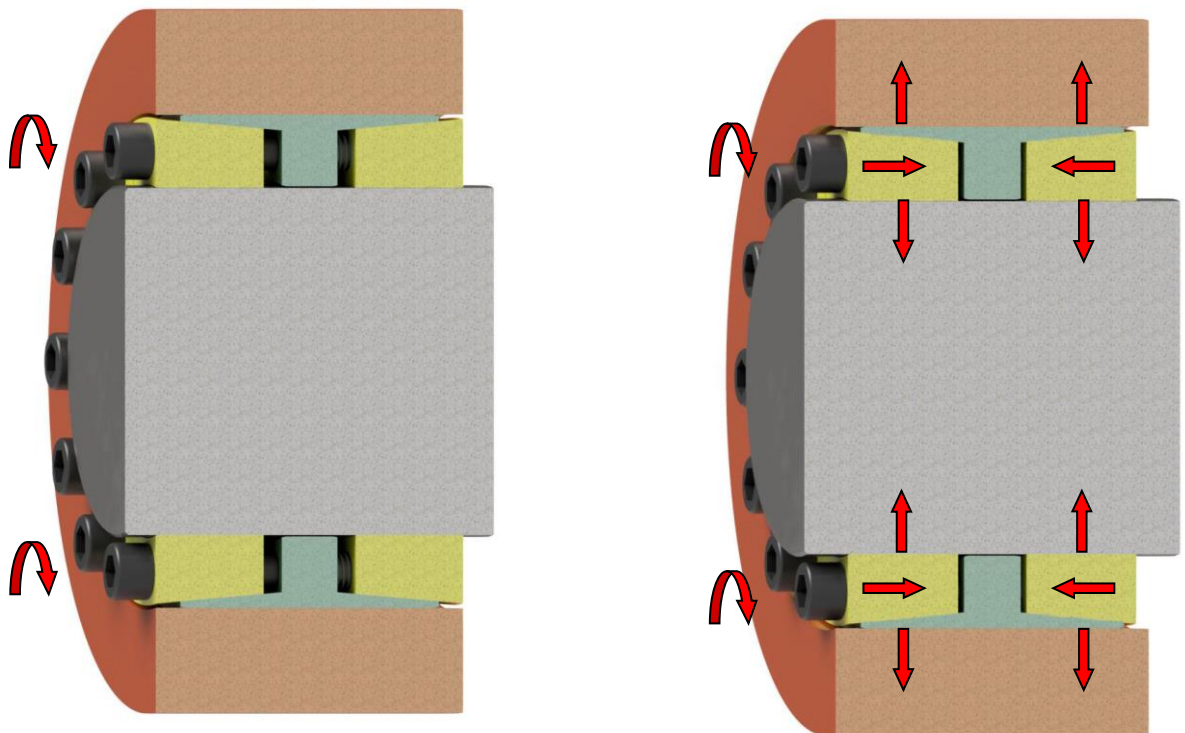

The locking assembly is maintenance-free and the screws do not have to be tightened after a certain period of operation.

Removal

1.

Loosen all screws and unscrew all screws as there are release threads.

As a rule, the number of screws corresponds to the number of release threads in the front and rear thrust ring.

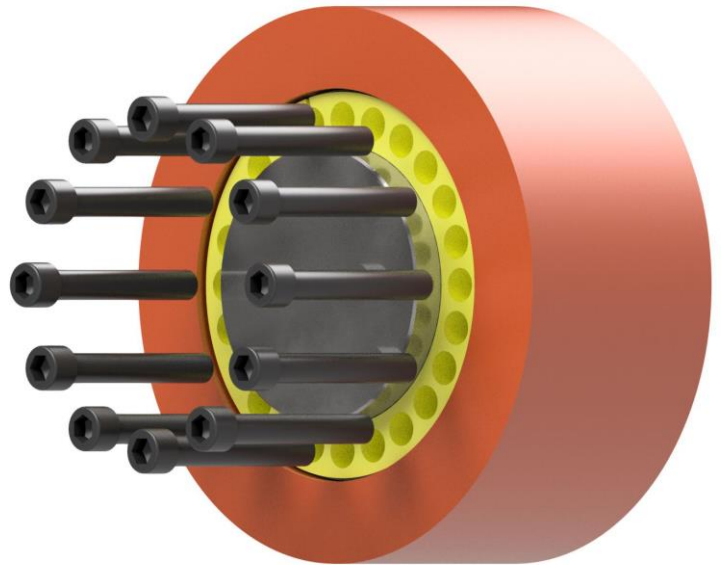

2.

Oil the screws and screw them into the release threads of front and rear thrust ring and tighten them **all** crosswise with a torque wrench until the thrust rings slide off the shaft and outer ring.

Important !

The shaft must be clean and free of particles. The thrust rings slide on the shaft when loosened.

(Grind the release screws flat on the face side before screwing them in)

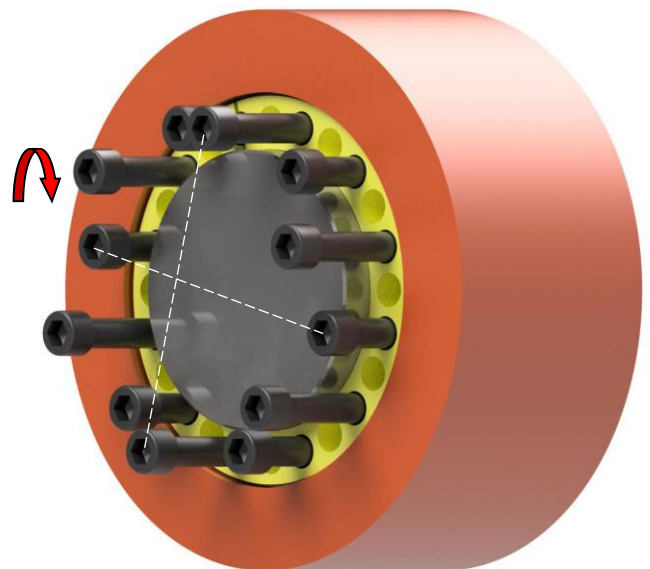

Removal

3.
The thrust rings slide on the shaft and outer ring and release the connection.

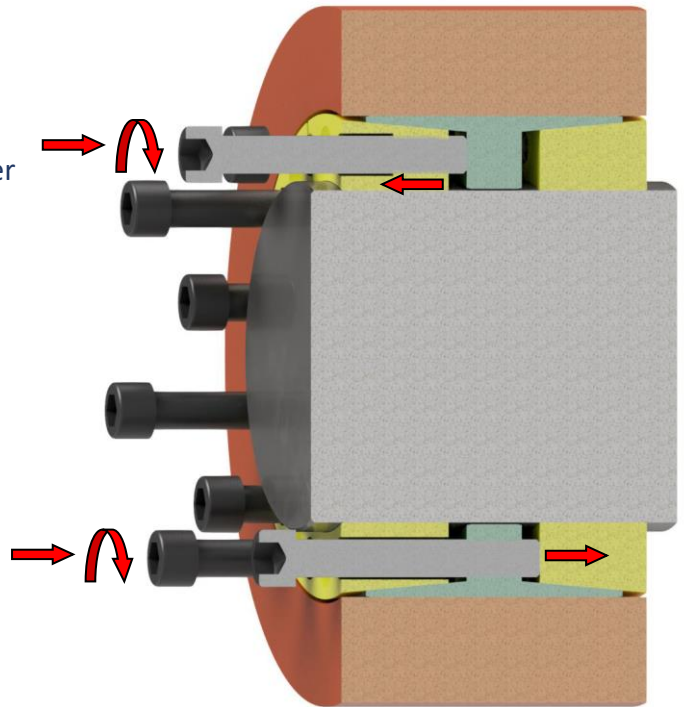

4.
Remove the locking assembly from the space.

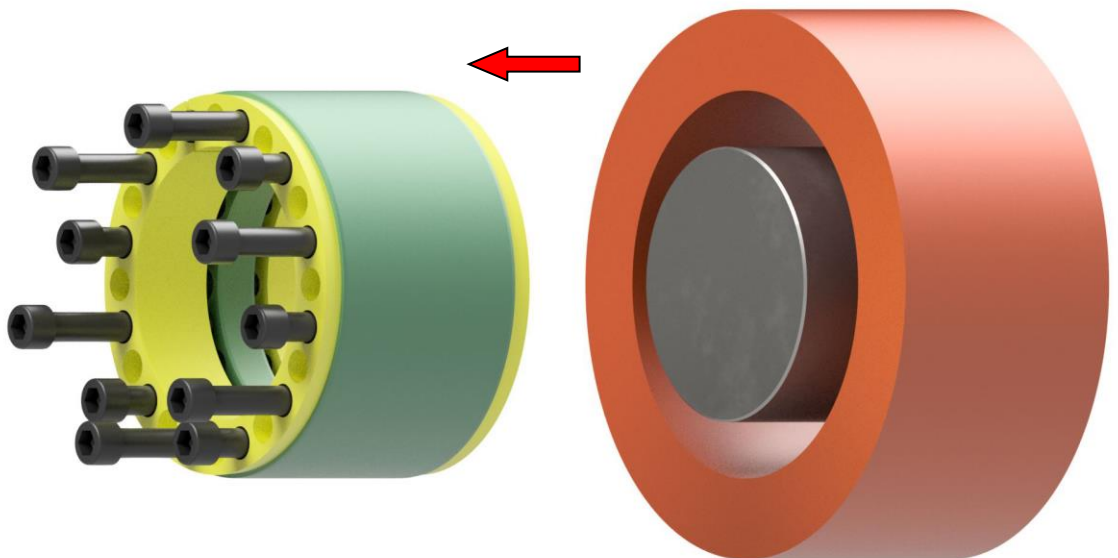

Reusability

Undamaged locking assemblies can be reused.

The screws must be changed after each use!

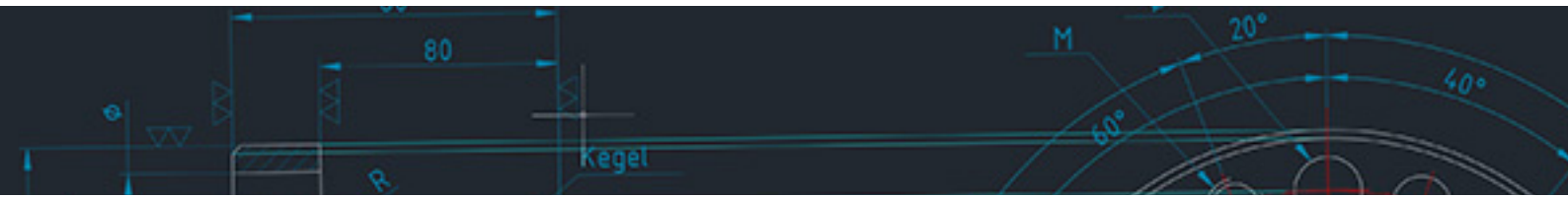

BIKON-Technik GmbH

Hansemannstrasse 11

41468 Neuss • Germany

Tel. ++49 (0) 2131-71889-0

www.bikon.de

E-Mail info@bikon.de