

BIKON 7000.B
Installation Manual

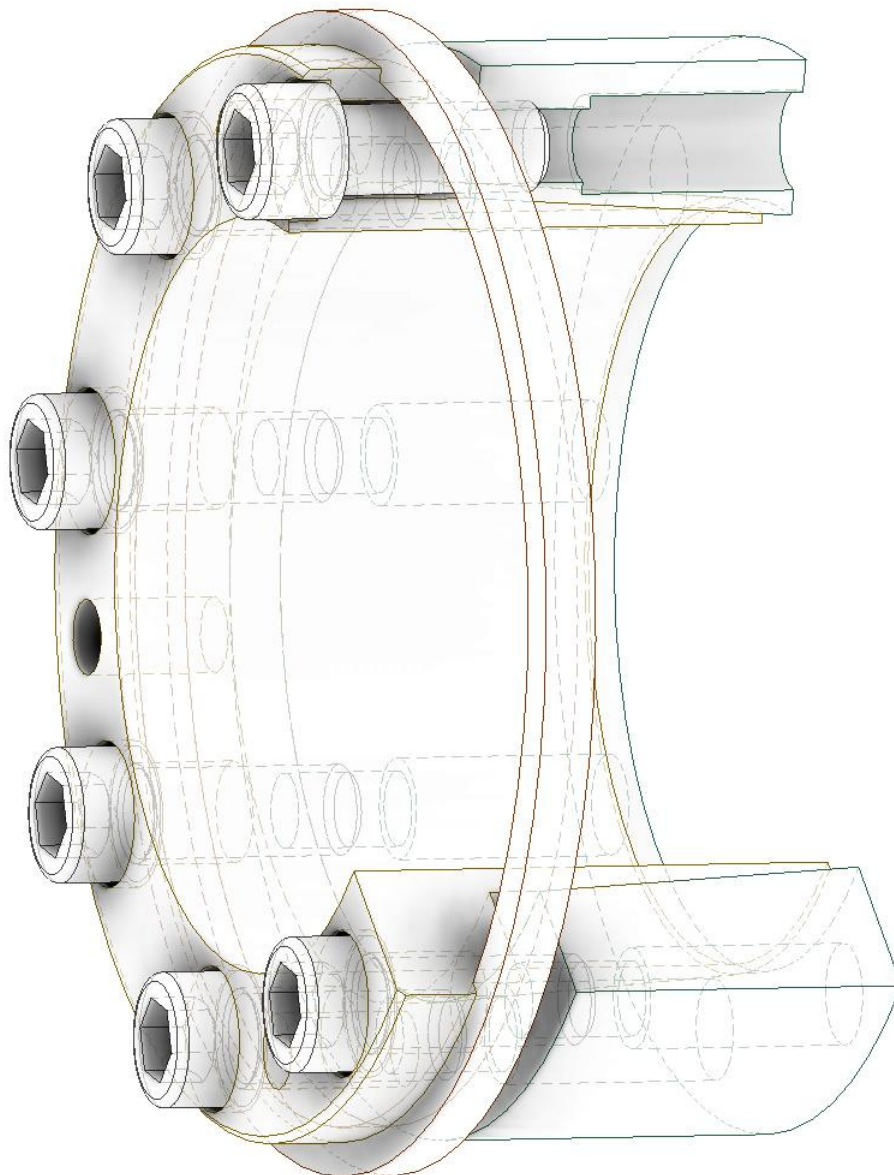

Only available from BIKON-Technik GmbH • 41468 Neuss • Germany

Index:

We reserve all rights with regard to this technical data and its content. Without our prior written approval it is not allowed to duplicate this technical data or parts of it, nor to grant access to it by third parties or to exploit it otherwise (including extracts) without authority.

All topics and specification dealt with are only valid for original „BIKON“ or „DOBIKON“ products.

We will not accept any liability for damages arising from misinterpretation, application or constructional flaws (regarding equipment wherein our products shall be installed). All information is based upon our knowledge of the current state of the art at the draft date of this technical data.

We refer to our trademark and further intellectual property rights as well as our conditions of sale that shall apply.

April 2023

BIKON 7000.B

Schematic scetch

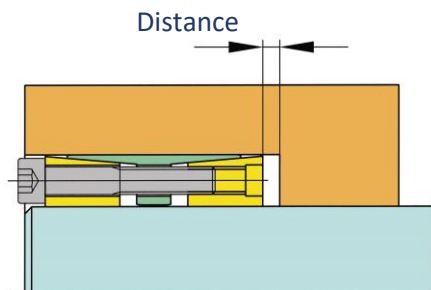

Space - generally

By use of stepped bores the locking assembly should never be pushed to block against the hub. There must be let distance about 2 – 5 mm to the hub to be able to remove the rings from each other. This applies to all BIKON locking assemblies.

Shafts with keyways

BIKON Locking assemblies can be tighten over keyways (according to DIN) on shafts. The function of the locking assembly is not affected.

Keyways in the hub are not allowed !

Space - BIKON 7000.B

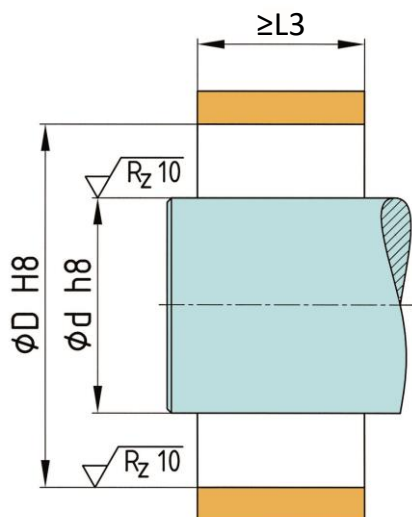

d	D	L2
mm	mm	mm
19	47	30
20	47	30
22	47	30
24	50	30
25	50	30
28	55	30
30	55	30
32	60	30
35	60	30
38	65	30
40	65	30
42	75	35

d	D	L2
mm	mm	mm
45	75	35
48	80	35
50	80	35
55	85	35
60	90	35
63	95	35
65	95	35
70	110	45
75	115	45
80	120	45
85	125	45
90	130	45

d	D	L2
mm	mm	mm
95	135	45
100	145	52
110	155	52
120	165	52
130	180	52
140	190	59
150	200	59
160	210	59
170	225	59
180	235	59
190	250	59
200	260	82

TA – Tightening torque of screws

d	M	TA
mm	-	Nm
19	M6	17
20	M6	17
22	M6	17
24	M6	17
25	M6	17
28	M6	17
30	M6	17
32	M6	17
35	M6	17
38	M6	17
40	M6	17
42	M8	41

d	M	TA
mm	-	Nm
45	M8	41
48	M8	41
50	M8	41
55	M8	41
60	M8	41
63	M8	41
65	M8	41
70	M10	83
75	M10	83
80	M10	83
85	M10	83
90	M10	83

d	M	TA
mm	-	Nm
95	M10	83
100	M12	145
110	M12	145
120	M12	145
130	M12	145
140	M14	230
150	M14	230
160	M14	230
170	M14	230
180	M14	230
190	M14	230
200	M14	230

Installation

1.

BIKON locking assemblies are delivered ready for installation and oiled. The screws have been unscrewed a few threads.

Make sure that the rings fit loosely on top of each other (self-locking cone).

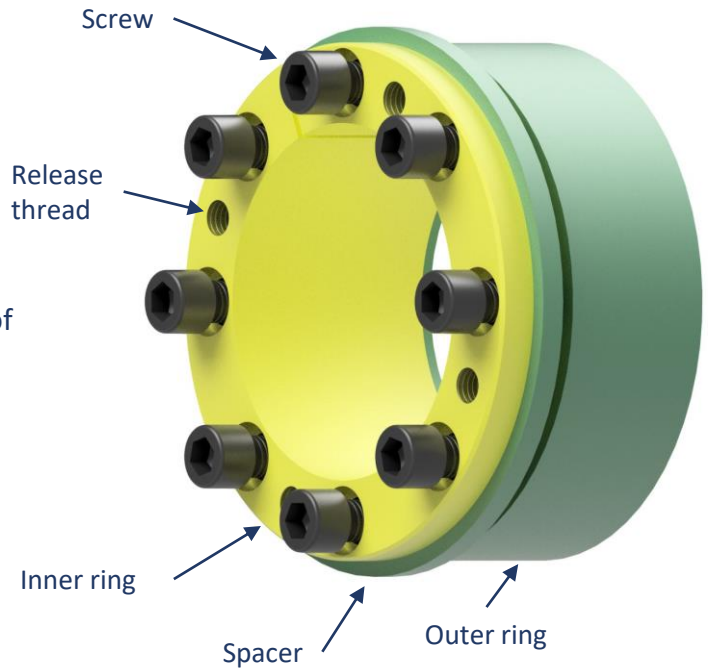

2.

Oil the shaft and hub and push the locking assembly into the installation space.

Do not use molybdenum disulfide (MoS₂), assembly paste or grease!

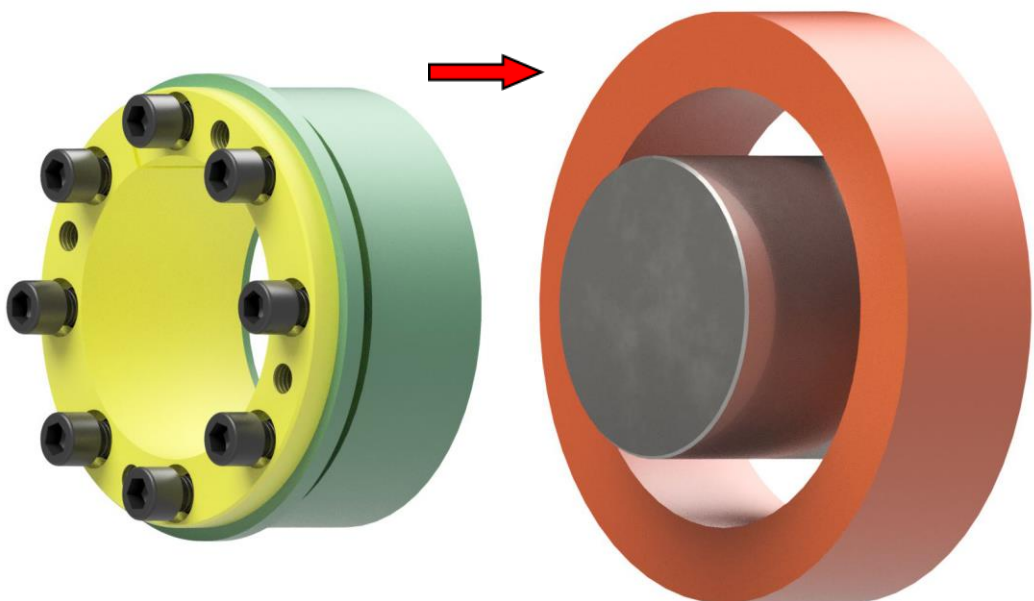

Installation

3.
The locking assembly must sit flush with the hub.

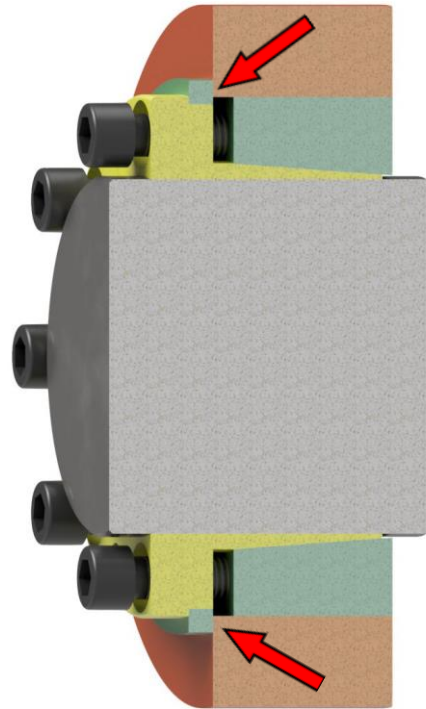

4.
Tighten the screws evenly crosswise and in several stages using a torque wrench.

control !

The tightening of the screws and the assembly is complete when no more screws can be tightened with the 100% tightening torque.

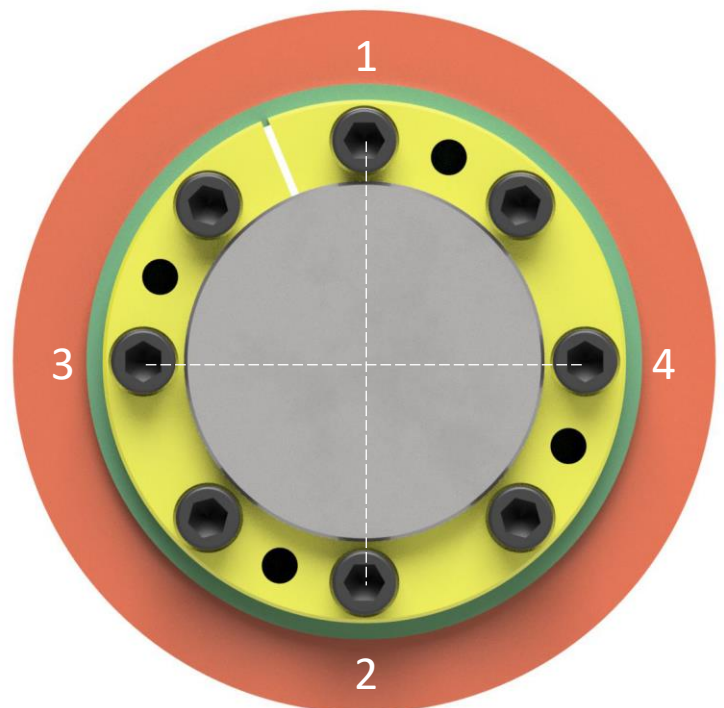

Installation

5.

By tightening the screws, the outer ring slides and tightens the connection. The cone is self-locking and will not loosen by itself if the screws are loosened if it is operated properly.

The hub does not move in the axial direction during assembly.

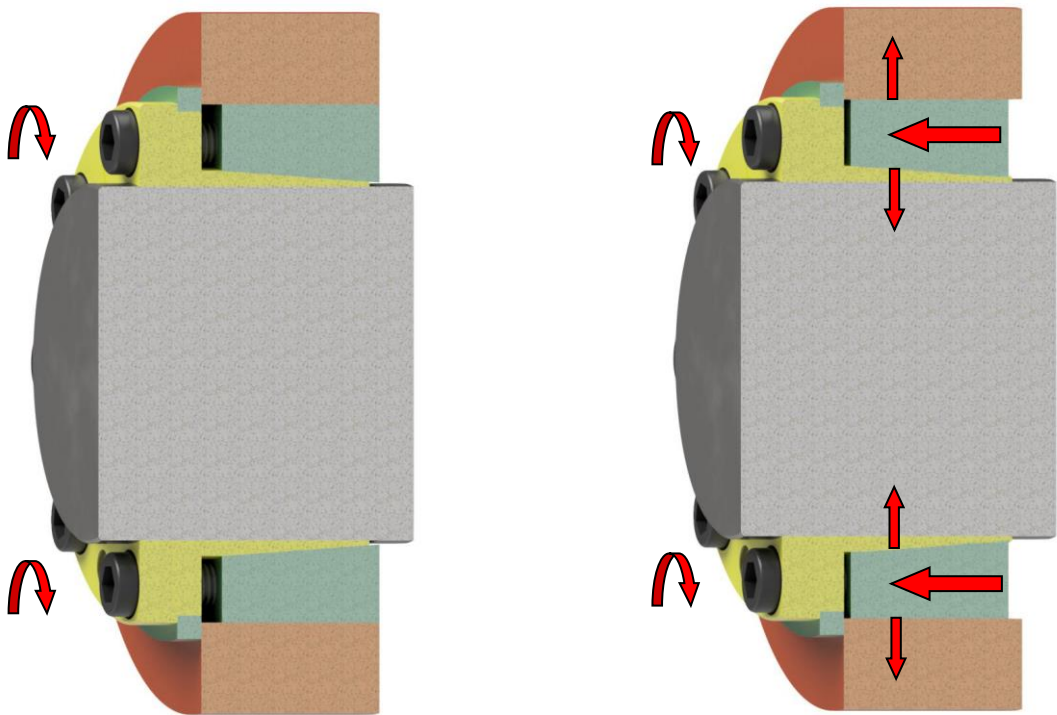

The locking assembly is maintenance-free and the screws do not have to be tightened after a certain period of operation.

Removal

1.

Loosen all screws a few threads.
Unscrew as many screws as there are release threads.

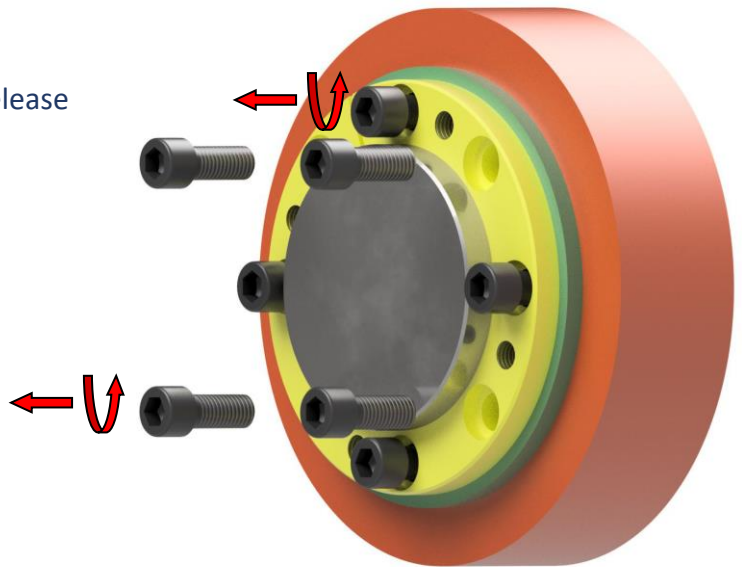

2.

Oil the screws and screw them into the release threads and tighten them crosswise with a torque wrench until the outer ring slides off the inner ring.

(Grind the release screws flat on the face side before screwing them in)

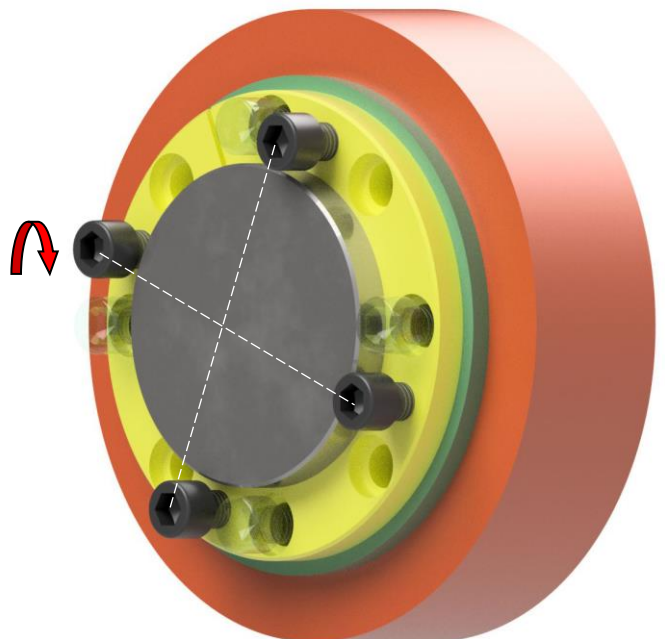

Removal

3.
The outer ring slides off the inner ring.

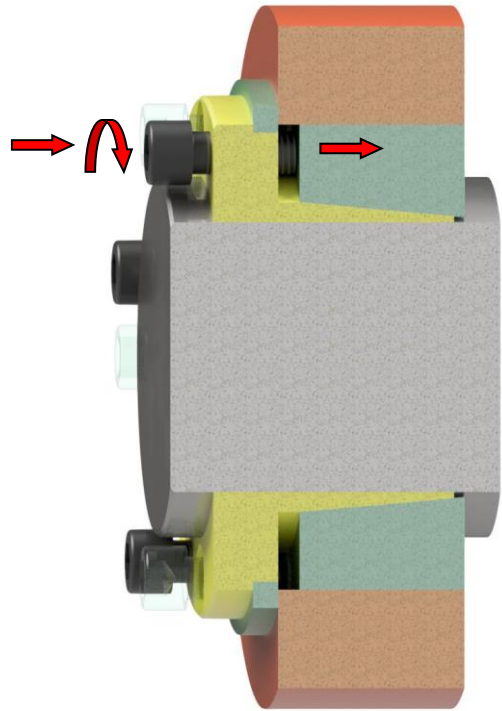

4.
Remove the locking assembly from the space.

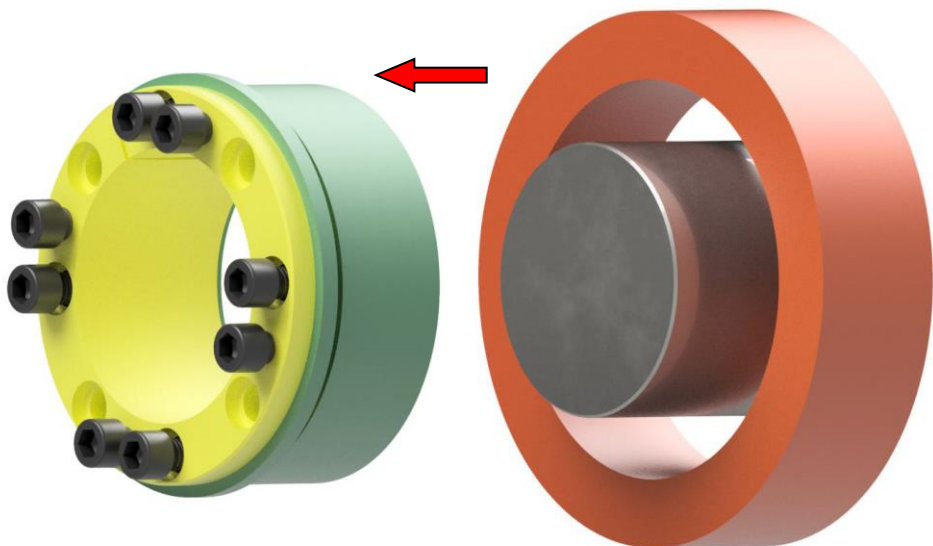

Reusability

Undamaged locking assemblies can be reused.

The screws must be changed after each use!

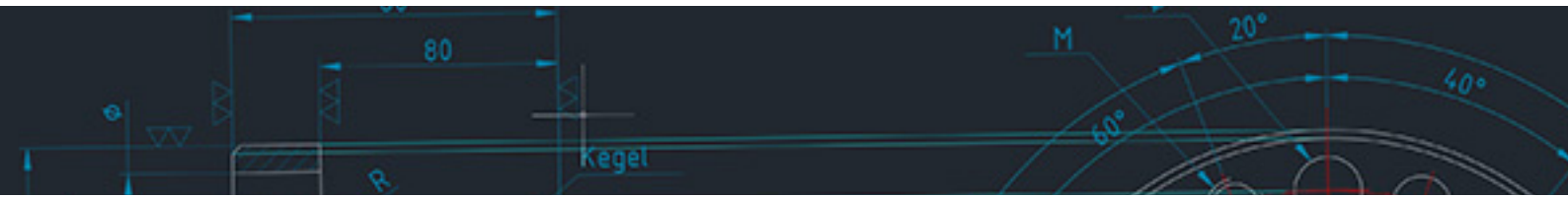

BIKON-Technik GmbH

Hansemannstrasse 11

41468 Neuss • Germany

Tel. ++49 (0) 2131-71889-0

www.bikon.de

E-Mail info@bikon.de