

**BIKON 2066**  
Installation Manual

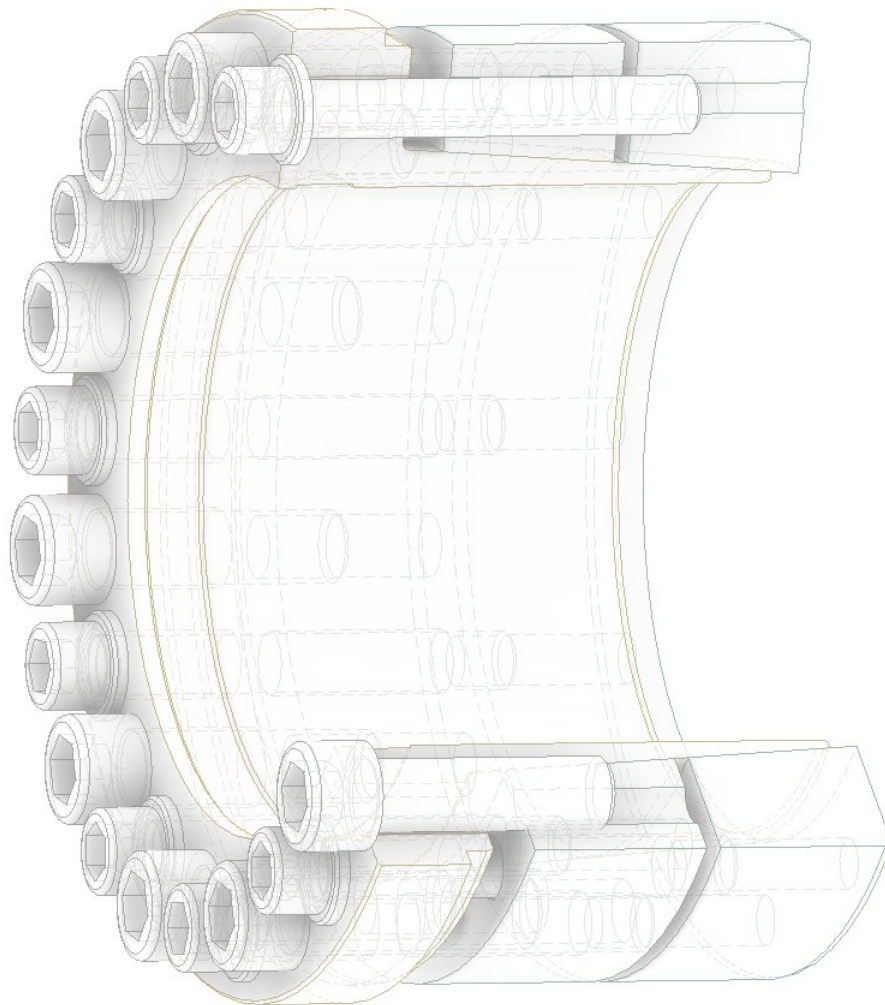

Only available from BIKON-Technik GmbH • 41468 Neuss • Germany

A development of BIKON-Technik GmbH - introduction on global market in year 2013

## Index:

We reserve all rights with regard to this technical data and its content. Without our prior written approval it is not allowed to duplicate this technical data or parts of it, nor to grant access to it by third parties or to exploit it otherwise (including extracts) without authority.

All topics and specification dealt with are only valid for original „BIKON“ or „DOBIKON“ products.

We will not accept any liability for damages arising from misinterpretation, application or constructional flaws (regarding equipment wherein our products shall be installed). All information is based upon our knowledge of the current state of the art at the draft date of this technical data.

We refer to our trademark and further intellectual property rights as well as our conditions of sale that shall apply.

March 2023

Schematic scetch

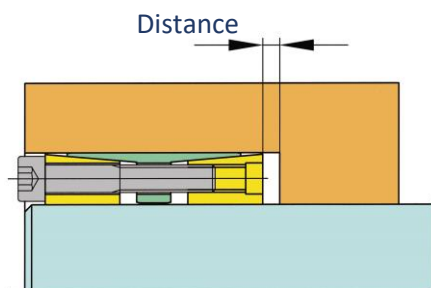

## Space - generally

By use of stepped bores the locking assembly should never be pushed to block against the hub. There must be let distance about 2 – 5 mm to the hub to be able to remove the rings from each other. This applies to all BIKON locking assemblies.

## Shafts with keyways

BIKON Locking assemblies can be tighten over keyways (according to DIN) on shafts. The function of the locking assembly is not affected.

**Keyways in the hub are not allowed !**

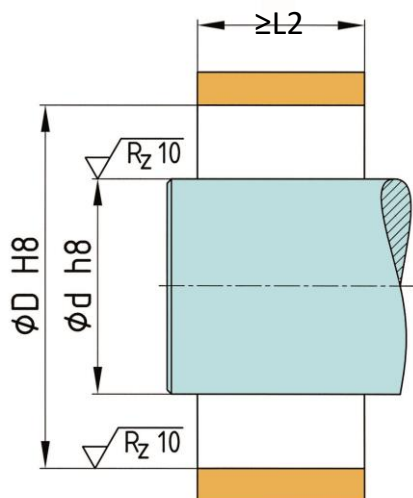

## Space - BIKON 2066

d	D	L2	d	D	L2	d	D	L2
mm	mm	mm	mm	mm	mm	mm	mm	mm
180	260	124	380	480	150	600	700	180
190	270	124	400	500	150	620	720	180
200	280	124	420	520	150	640	740	180
220	300	124	440	540	180	660	760	180
240	320	124	460	560	180	680	780	180
260	340	124	480	580	180	700	800	180
280	380	150	500	600	180	720	820	183
300	400	150	520	620	180	740	840	183
320	420	150	540	640	180	760	860	183
340	440	150	560	660	180	780	880	183
360	460	150	580	680	180	800	900	183

## TA – Tightening torque of screws

d	M1	TA1	M2	TA2
mm	-	Nm	-	Nm
180	M20	690	M16	355
190	M20	690	M16	355
200	M20	690	M16	355
220	M20	690	M16	355
240	M20	690	M16	355
260	M20	690	M16	355
280	M24	1 200	M20	690
300	M24	1 200	M20	690
320	M24	1 200	M20	690
340	M24	1 200	M20	690
360	M24	1 200	M20	690

d	M1	TA1	M2	TA2
mm	-	Nm	-	Nm
380	M24	1 200	M20	690
400	M24	1 200	M20	690
420	M24	1 200	M20	690
440	M24	1 200	M20	690
460	M24	1 200	M20	690
480	M24	1 200	M20	690
500	M24	1 200	M20	690
520	M24	1 200	M20	690
540	M24	1 200	M20	690
560	M24	1 200	M20	690
580	M24	1 200	M20	690

d	M1	TA1	M2	TA2
mm	-	Nm	-	Nm
600	M24	1 200	M20	690
620	M24	1 200	M20	690
640	M24	1 200	M20	690
660	M24	1 200	M20	690
680	M24	1 200	M20	690
700	M24	1 200	M20	690
720	M24	1 200	M20	690
740	M24	1 200	M20	690
760	M24	1 200	M20	690
780	M24	1 200	M20	690
800	M24	1 200	M20	690

## Installation

1. BIKON locking assemblies are delivered ready for installation and oiled. The screws have been unscrewed a few threads.

Make sure that the rings fit loosely on top of each other (self-locking cone).

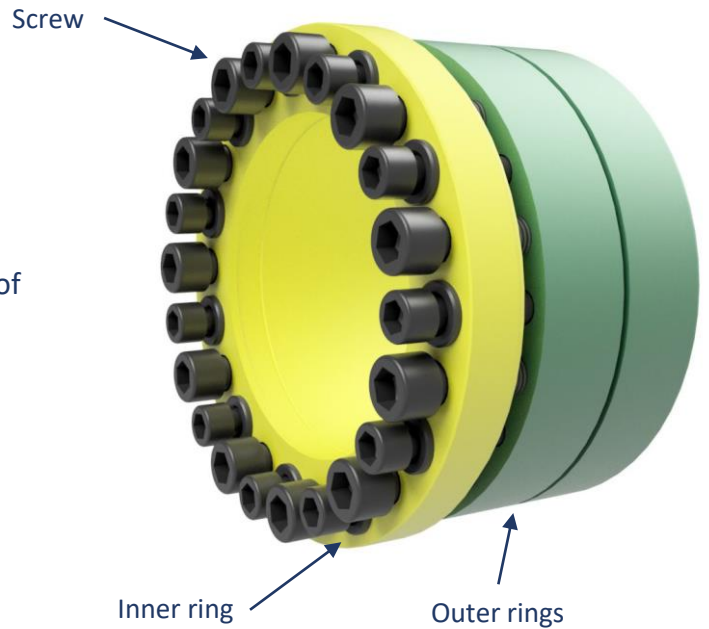

2. Oil the shaft and hub and push the locking assembly into the installation space.

**Do not use molybdenum disulfide (MoS<sub>2</sub>), assembly paste or grease!**

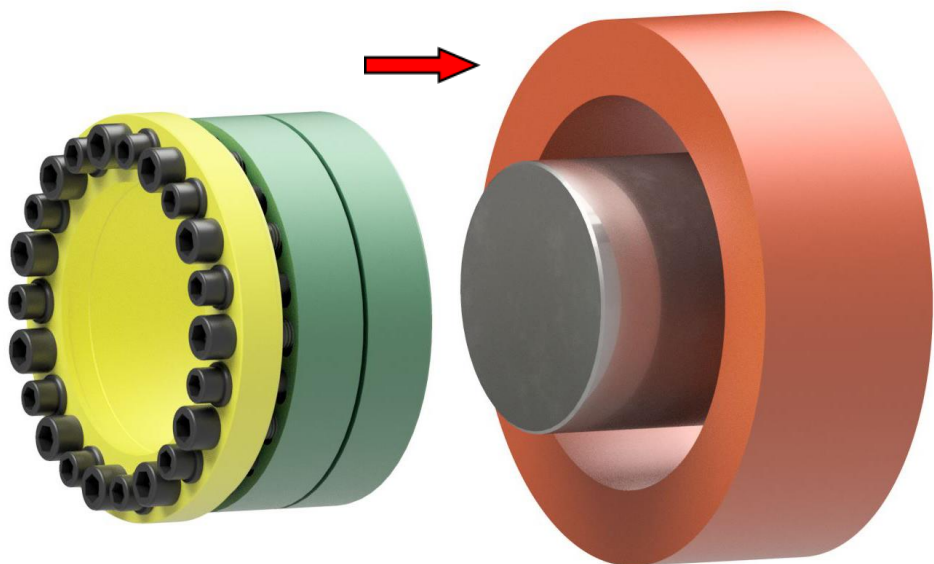

## Installation

**3.**

The locking assembly must sit flush with the hub.

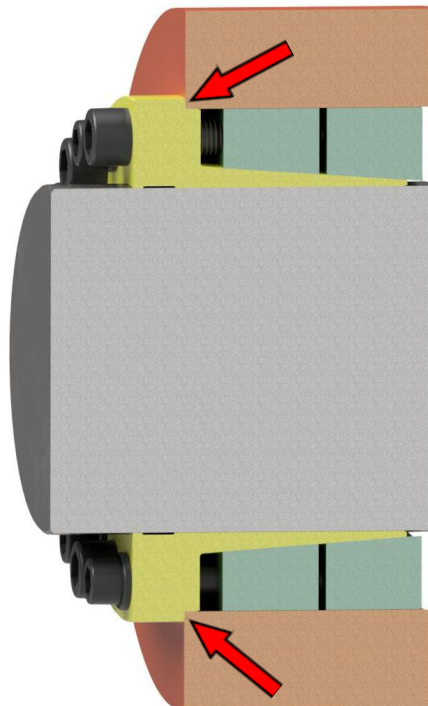

**4.**

Tighten the screws evenly crosswise and in several stages, starting with the smaller screws, using a torque wrench.

Repeat the same procedure for the bigger screws.

### **control !**

The tightening of the screws and the assembly is complete when no more screws can be tightened with the 100% tightening torque.

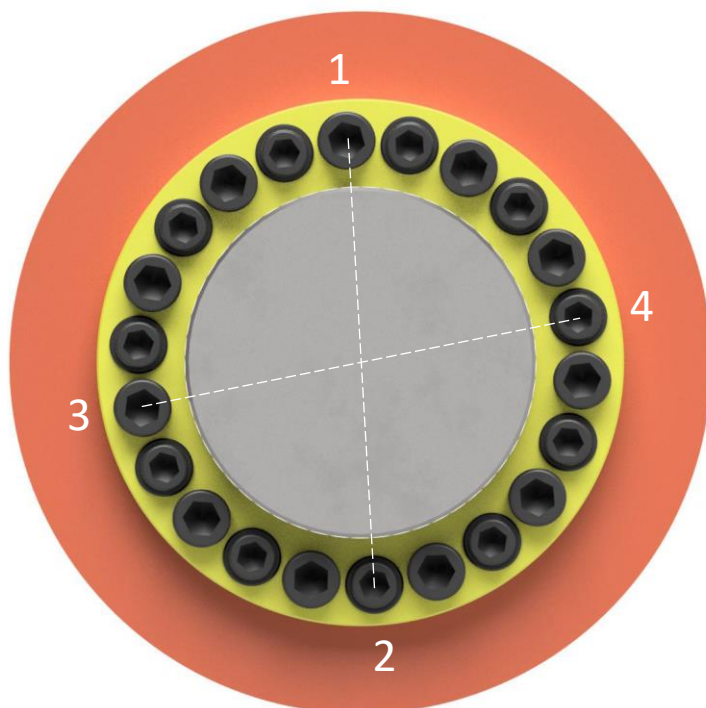

## Installation

5.

By tightening the screws, the outer rings slides and tightens the connection. The cone is self-locking and will not loosen by itself if the screws are loosened if it is operated properly.

The hub does not move in the axial direction during assembly.

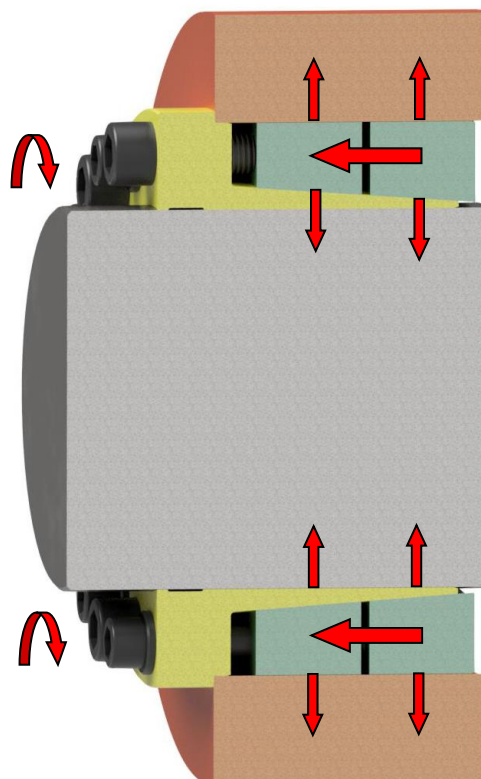

The locking assembly is maintenance-free and the screws do not have to be tightened after a certain period of operation.

## Removal

1.

Loosen and unscrew all screws with washers.

The release threads become visible.

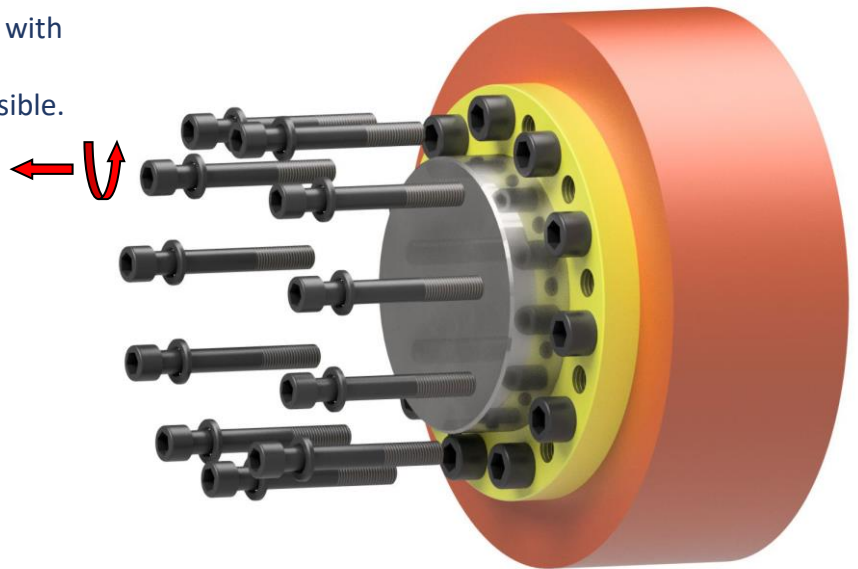

2.

Loosen the remaining, larger screws and unscrew them a few turns.

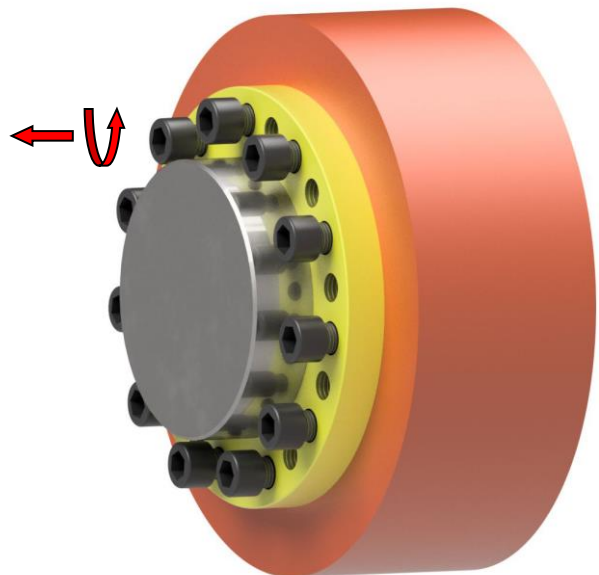

## Removal

3.  
Place the removing ring on the screw heads.

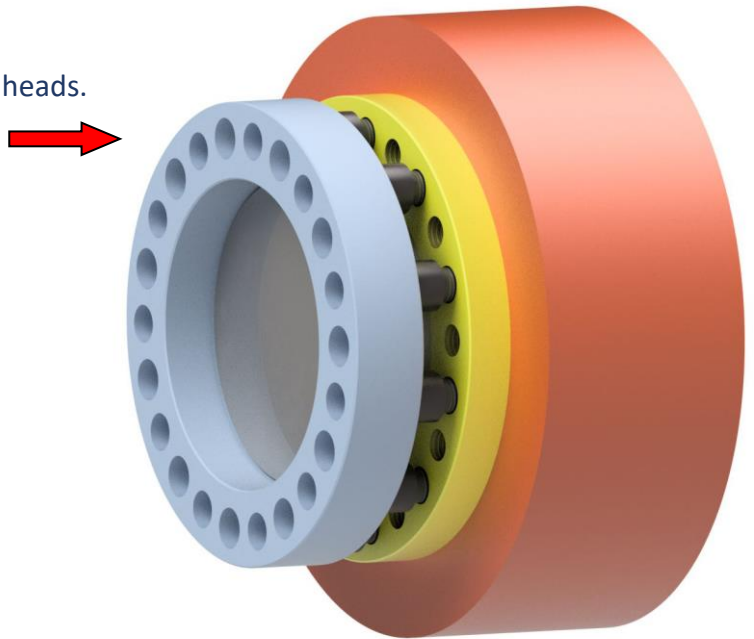

4.  
Screw the screws through the removing ring into the release threads and tighten crosswise using a torque wrench.

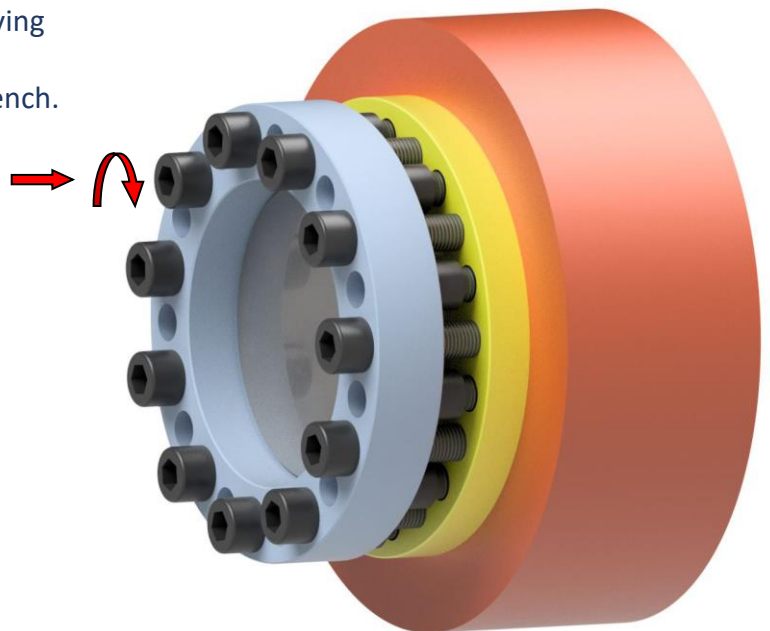



## Removal

5.  
The thrust rings are pressed off via the screws and thus released.

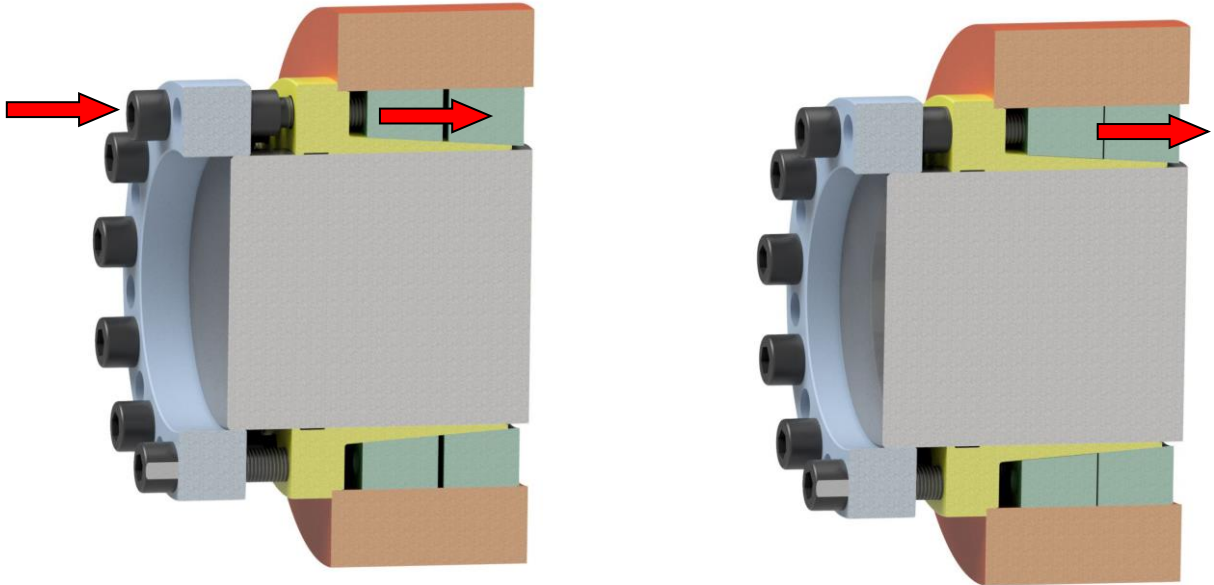

Removing ring on request

6.  
Remove the locking assembly from the space.

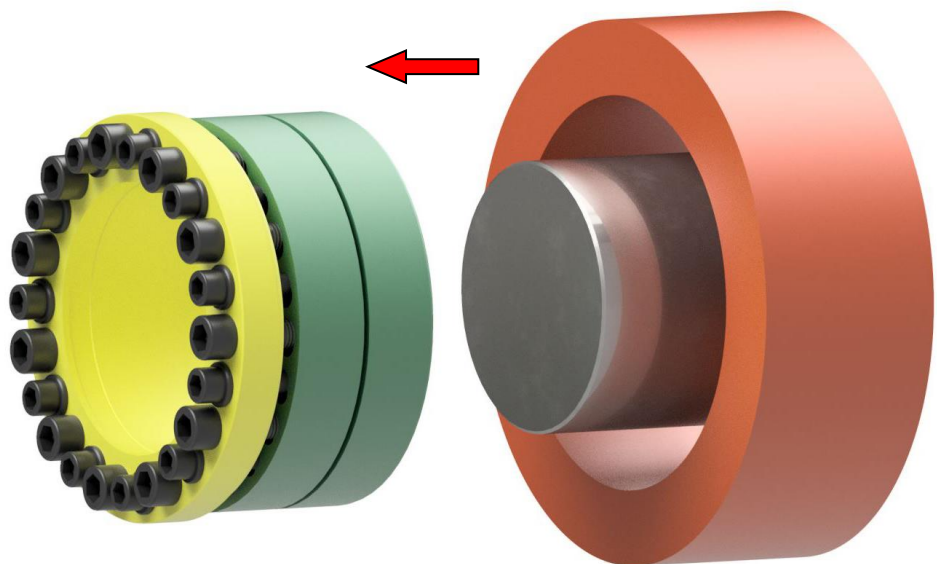

### Reusability

Undamaged locking assemblies can be reused.

**The screws must be changed after each use!**

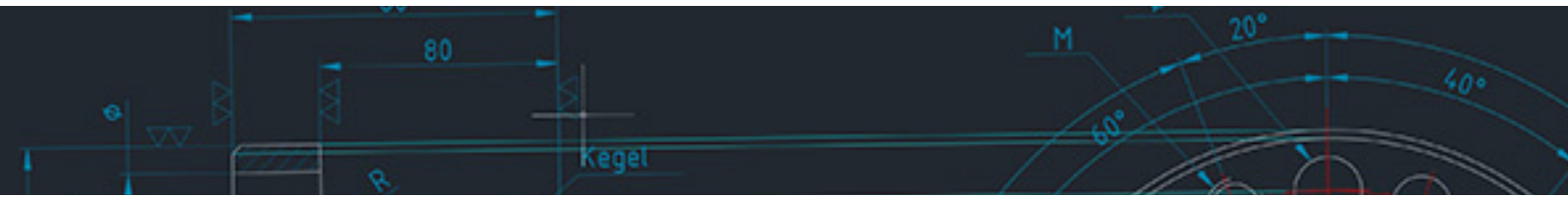

## **BIKON-Technik GmbH**

Hansemannstrasse 11

41468 Neuss • Germany

Tel. ++49 (0) 2131-71889-0

[www.bikon.de](http://www.bikon.de)

E-Mail [info@bikon.de](mailto:info@bikon.de)